

Model J15

Installation Manual

DIMAC

❖ Accessories

Description of good	J15
Bracket for machine	Exclusive type
Electrical cable	P6: 8M
Emergency cable	8M
Air hose	8*5: 6M
Air regulator	With air filter
Bolts	
① for the bracket	2-M12*30
② for the machine	4-M8*15
③ pass line adjusting	1-M12*120
Fixture for the air regulator	2-M6*12
④ Bonding	Net 4ml
Mark tube, Terminal	Assortment
Sticker	Signal(Feed/Release), Scale for pass line(on the bracket)
Air connector	1-TS8-03, 2-NTS8-02
⑤ Apron plate	Exclusive type

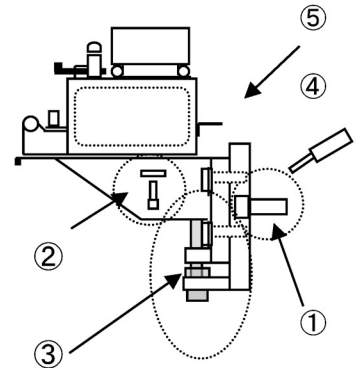

❖ Method of Input

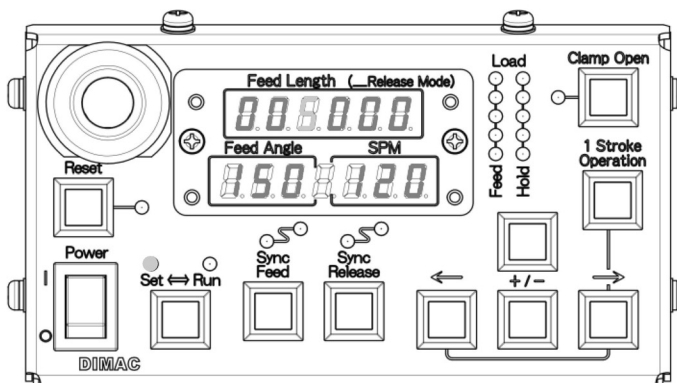





- ① **Power** Turn on "Power" switch
- ② **Set ↔ Run** You can input a set value when "Set" lamp is lit. Numeric value that can be changed item or number will be blink.
- ③ ← → Using the switches, you can move the cursor position.
- ④ +/- Using the switches, you can change the value.

If you need to continue inputting, repeat the ③, ④.

After setting

- ⑤ **Set ↔ Run** Push "Set ↔ Run" switch, when "Run" lamp is lit, the setting

⑥	 Sync Feed 	 Sync Release 	Press the both switches of Sync Feed and Sync Release switches, then the controller will be able to receive the sync press cam signals.
---	---	--	---



Usually, the Release mode does not display. Only when changing settings item, the Release mode is supposed to display on the "Feed Length" after displaying digit of lowest of "Feed Length"

❖ J15 Pass line

The pass line height is decided by combination a plate and a holder.

CAUTION The plate-center equals the feeding rolls -center.

It is necessary to tighten 4 points with a bolt to fix the holder on the plate.

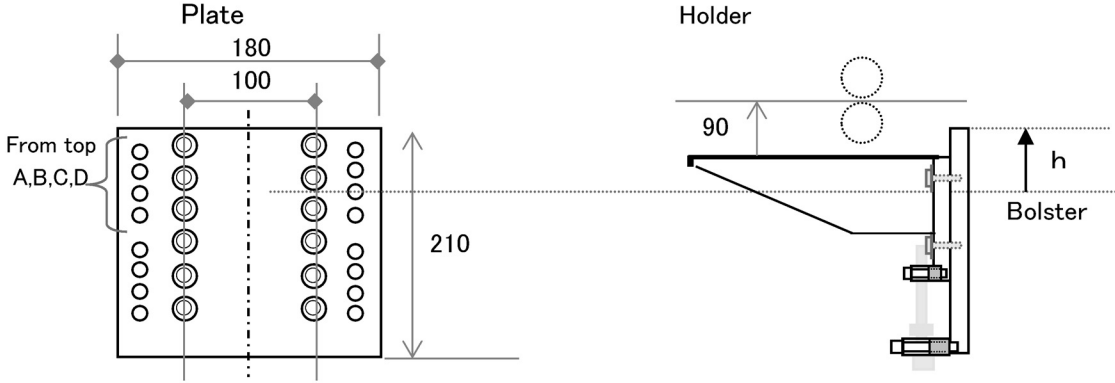
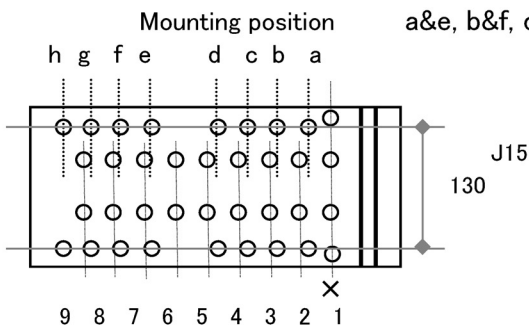

Plate height	Hole position	Pass line (mm)	Plate height	Hole position	Pass line (mm)
h=0	A	98~148	h=75	A	173~223
	B	83~133		B	158~208
	C	68~118		C	143~193
	D	53~103		D	128~178
h=25	A	123~173	h=100	A	198~248
	B	108~158		B	183~233
	C	93~143		C	168~218
	D	78~128		D	153~203
h=50	A	148~198	h=125	A	223~273
	B	133~183		B	208~258
	C	118~168		C	193~243
	D	103~153		D	178~228

❖ Mounting position

Top view



a&e, b&f, c&g, d&h 1: not use (2~9:for J06)

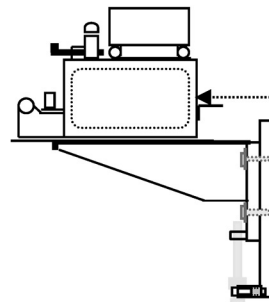

❖ Balance of confirmation

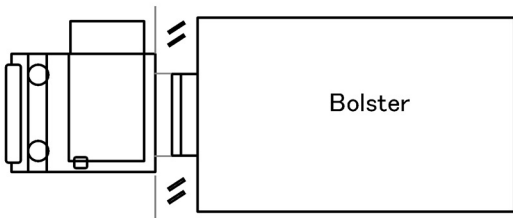

❖ Assembly drawing of the bracket

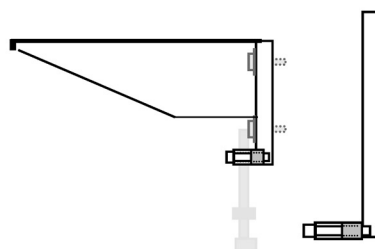

❖ Wiring

You can select which 3 phase or single phase. If it's single phase, you don't have to connect the black wire.

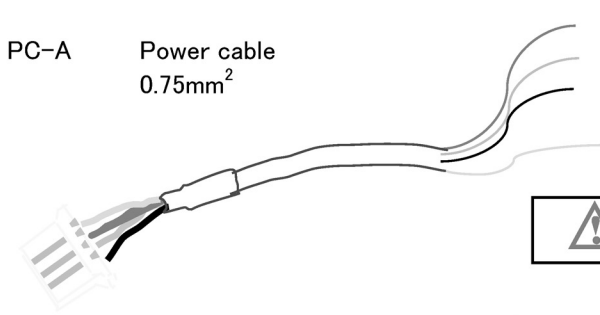

- Red R(200V 50/60Hz)
- White S(200V 50/60Hz)
- Black T(200V 50/60Hz)
- Not wiring when single phase
- Green/Yellow E(Earth)

DANGER Connect to the primary side

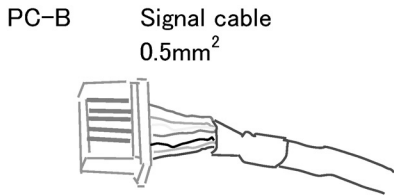

Wire #

1:2 1A at AC 250V or less

3:4 1A at DC 30V or less

5:6

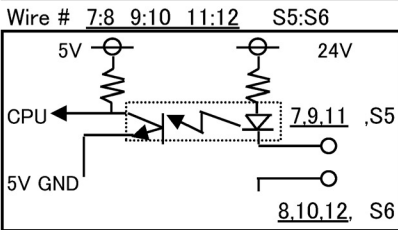

Wire # 1A at AC 250V or less

S1:S2 1A at DC 30V or less

S3:S4

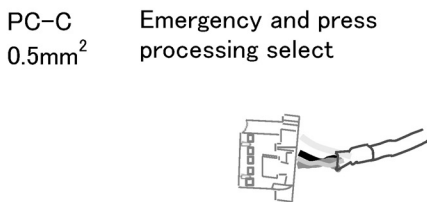

- 1 Drive stop signal output } To the stop continuous on the press circuit
- 2 Option
- 3 Work shortage sensor } To the stop continuous on the press circuit
- 4 output
- 5 Continuous stop signal } To the stop continuous on the press circuit
- 6 output

7 Input stop of Feeder

8 24V GND

CAUTION
Need to short, if not using.

Example for circuit

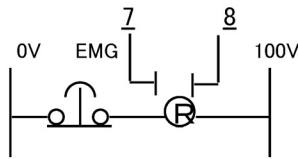

- 9 Feed input
 - 10 24V GND
 - 11 Release input
 - 12 24V GND
- Press cam signal

- S1 White: Emergency stop
 - S2 Black: Emergency stop
 - S3 Red: Emergency stop
 - S4 Green: Emergency stop
- To Emergency stop circuit

Option

S5 Yellow: Press cont. processing

S6 Blown: 24V GND

CAUTION
Need to short, if not using.

Need to short the circuit of press processing select(S5, S6), if you don't use the circuit.

DANGER To cover each cable which is not using connection.

❖ Cable connecting

The receptacles of PC-A, PC-B, PC-C are placed inside the connecting cover.

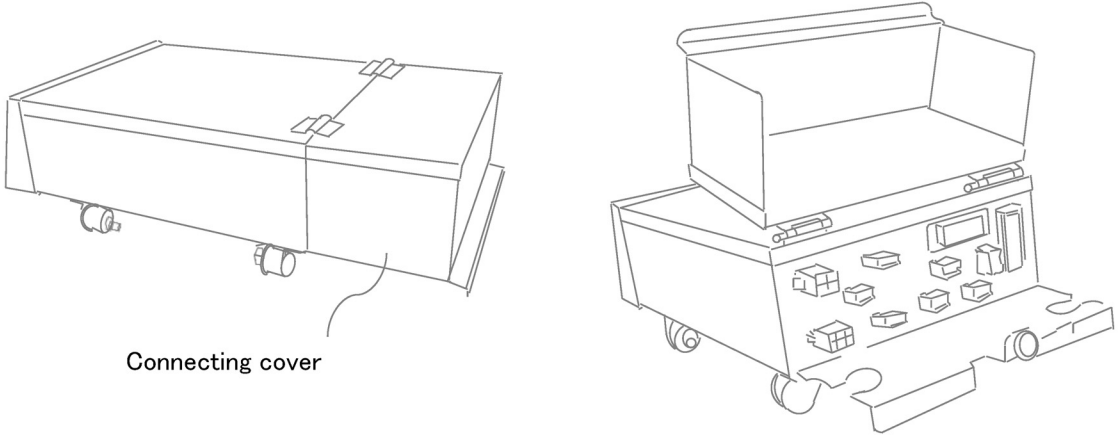

Connecting cover

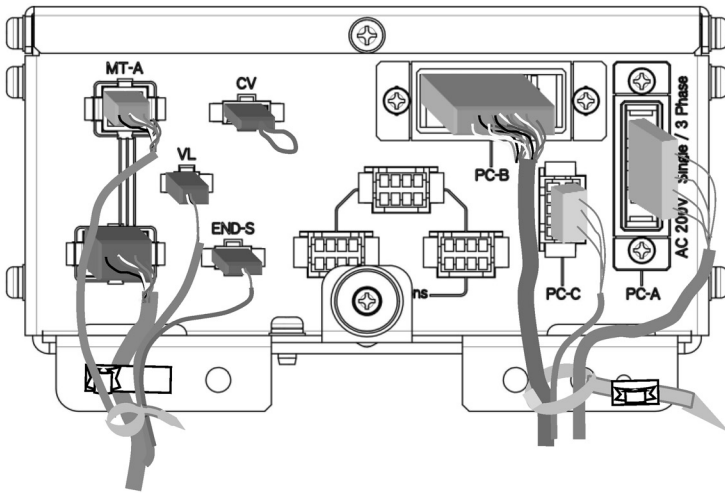

	DANGER Need to fix three external cables in prepared nylon band.
--	---

❖ Air piping

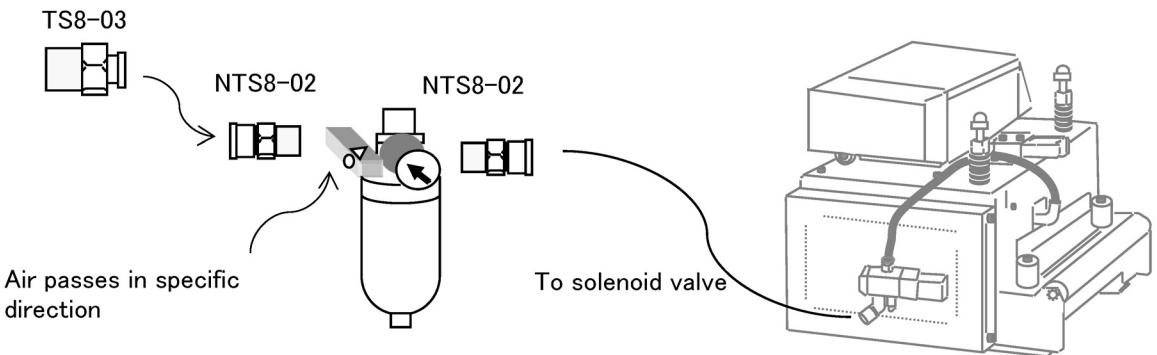

	CAUTION *Approximate air pressure : 0.3~0.5 MPa *Maximum air pressure: 0.5 MPa
--	--

❖ Adjusting Press cam signals

Feed signal adjusting

Set the feed start position to feed signal OFF position.
 When you make the feed starts on 270° ,
 Set the ON angle of feed to 240° , and set the OFF angle to 270°

	NOTE
Need to set the ON of the feed signal to the feed completed angles when using option "Overrun-Function".	

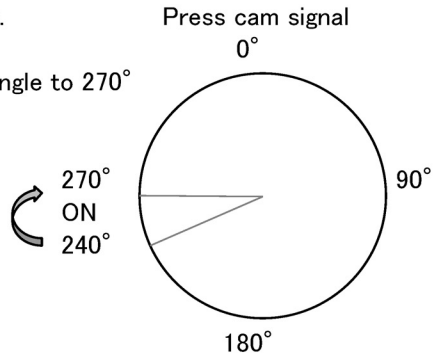

Release signal adjusting

Set the ON to the release start angle, and set the OFF to the finish.
 When the release angle is assumed to 200° from 200° ,
 you turn on the press cam signal in 110 degrees,
 and turn off in 200 degrees.

The retention angles of the release ON must be 25 degrees or more.

Need to adjust the signal of the release start even if the release system is used a time setting of timer or angles.

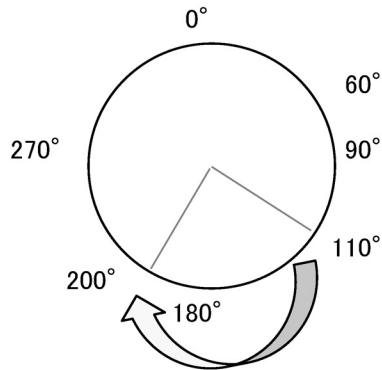

❖ Release setting in the controller 【 (_ Release Mode) 】

【 (_ Release Mode) 】 The display is the back screen of 【 Feed Length 】.
 The Release mode is supposed to display on the "Feed Length" after displaying digit of lowest of "Feed Length"

Using "+" or "-" switch, Set the release mode.

The Release mode are as follows, Release OFF, Synchronization press cam signal, Timer finish.

Display and contents

Feed Length (_ Release Mode)	Contents
-- Sync	Synchronization press cam signal
-- OFF	Invalid the release signal, Release off state.
-- RO1 ~	Release angles setting. It can be input from 1° to 50° . The control calculates the release time from the setting SPM and the angles, the release will operate in the time range.
-- RSO	Input the release start using the press cam signal.
-- T01 ~	Release timer setting. It can be input from 0.001sec to 0.05 sec. Input time period, the release carry out.
-- T50	Input the release start using the press cam signal.

	NOTE	The release operation is delayed due to air cylinder. The delay time will vary depending in the springs pressure.
--	-------------	--

❖ Message code

Contents display : 【 Feed Length (_Release Mode) 】, Code number : 【 Feed Angle SPM 】

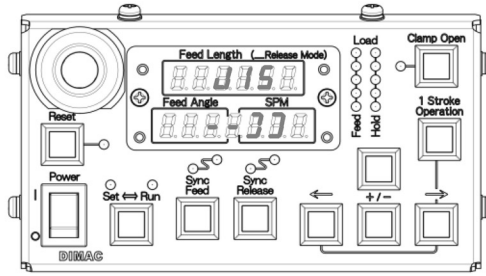

Feed Length	Feed Angle	SPM	Contents	Method of reset
J 15	- - } }		Ins. Left, Direction Push	When turning on power only, the control panel displays the program
	- - } }		Model	
	∟∟ - -		Ins.Right, Direction Pull	
	∟∟ - -		Ins. Left, Direction Pull	
ENG	444444		Emergency stop switch ON	After releasing the Emergency stop switch, turn off the power.
	444444		Emergency stop switch OFF	
STOP	∩ ∩ ∩		Input stop signal during driving press	Turn on Reset switch after input stop signal release
	∩ ∩ ∩		Input stop signal release	Turn on Reset switch
	∩ ∩ ∩		Input stop signal	Automatic reset
End	777777		Work shortage sensor ON	After setting a work pieces, turn on "Reset" switch
End_2	777777		Another work shortage sensor ON	
End	777777		Work shortage sensor release	Turning off "Sync Feed", the work shortage sensor will disabled.
End_2	777777		Another work shortage sensor release	
I - F	66 166 1		Interfere releasing	Turn on "Reset" switch
	662662		Input feed signal during feeding	Turn on "Sync Feed" and "Sync Release" after turn on "Reset" switch
	663663		Input feed signal during releasing	
	664664		Input release signal during feeding	
0_run	666666		Overrun	

❖ Caution display

This caution displays have a possibility which the feeder is reset. These displays are as the follows,
 Reset : Blinking. Feed Angle SPM : ∟. Number

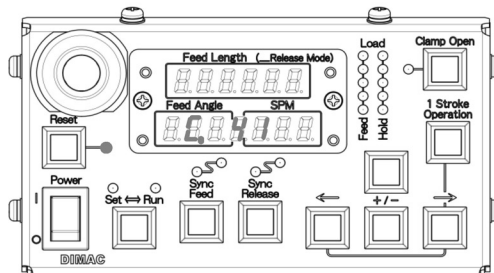

Code	Number	State / Content	Note
∟	40	Open phase	Confirmation of the power supply
∟	41	Low voltage detection	Checking the voltage
∟	10 - 1	Setting mistake of the motor capacity	Initial setting mistake
∟	10 - 2		
∟	50 - 1	Motor connection anomaly	Contact failure
∟	50 - 2		
∟	50 - 3	Malfunction of Rotation sensor	Setting mistake